



Endevco

Problems in high-shock measurement

Problems in high-shock measurement

Engineers and scientists for years have struggled trying to improve the quality of high-g shock measurement. The biggest challenge has always been to pinpoint the source(s) of the problem. This paper discusses a major source of errors — the shock accelerometer, and suggests a practical solution.

The input spectrum of high-g shock, be it mechanical or pyrotechnic, has always been underestimated by practitioners in the measurement industry, leading to improper test equipment selections. Furthermore, most transducer manufacturers have very limited experience in high-g shock test, and it is reflected in the design approaches of many so called “shock” accelerometers. This author suggests that, in close-range (near-field) high-g shock measurement, the accelerometer must be protected from all ultra high frequency input energy in order to avoid sensor resonance, which is the root cause of many problems in high-g shock measurement. This paper also outlines the ingredients of a true shock accelerometer.

With all the advances in digital data acquisition equipment and signal processing techniques, the acceleration transducer (accelerometer) is still the weakest link in a pyroshock measurement chain. Current design approaches in accelerometers, such as electronic filtering and high resonance, can not always guarantee the experimenters with repeatable performance and believable results.

The core of the problem has been identified to be the sensing element of the transducer. All sensing mechanisms are vulnerable to high-g excitation at frequencies far above our point of interest. These high frequency, high-g transients, although “invisible” to many recording systems, are present in all close-range pyrotechnic and metal-to-metal impact testings, methods that are commonly used in many shock qualification requirements.

The advantage of using a mechanical filter as an isolator is discussed. Isolating the sensing element (piezoelectric or piezoresistive) from high frequency transient attacks appears to be one of the most effective design improvements in shock accelerometer. A design with built in mechanical filter has allowed test engineers to record pyroshock time history without zershift, a common linearity error of the sensor in high g-shock measurement. This piezoelectric accelerometer features both an input mechanical filter and an electronic low-pass filter for sensor isolation and maximum bandwidth. Calibration data indicate flat frequency response to 10kHz with 24 dB per octave roll-off thereafter. Survivability of accelerometers in high-g environments has also greatly improved due to shock isolation provided by these filters.

Problems associated with high frequency energy

All undamped, spring-mass type accelerometers have a finite seismic resonance. When the resonance of such device is excited, integrity of the output signals is suspected. To ensure linear response and minimize error, spectrum of the acceleration input must stay within the transducer's recommended bandwidth. As a general rule-of-thumb, the maximum usable bandwidth for an undamped accelerometer is to be less than one fifth of the transducer resonance. This rule is generally well observed in the vibration-test community.

Unfortunately, the term maximum usable bandwidth is often mistaken for the available bandwidth of a Shock Response Spectrum by many test engineers. Since most Shock Response Spectra stop at 10kHz or 20 kHz, accelerometers with resonance in the neighborhood of 100 kHz are considered adequate for high g-shock applications, ignoring the fact that there is much energy beyond 20 kHz. The problem is further complicated by the issue of damage potential of high frequency. It is a well established fact that shock energy above 10 kHz seldom causes any damage to the test article, and it is routinely overlooked in most data analysis. These high frequency components, although posing no danger to the article, seriously affect the linear operation of any spring-mass type accelerometer.

It has been demonstrated that the input spectrum of most high-g shock measurements contains frequency components way above 100 kHz, [7], well beyond the capability of most recording devices. These high frequency components are often unnoticeable until something occurs during data acquisition; eg. aliasing of a digital recorder. The most commonly used wide-band analogue tape recorder can only capture time history up to 80 kHz (running at 120 inch/second), out-of band information is therefore naturally attenuated and "invisible" on playback.

Recently, a few papers and articles have been published [1] [2] concerning the effect of ultra-high frequency impulses on shock measurements. This out-of -band

transient phenomenon is referred to in the papers as "Pre-Pulse", stress wave that approximates a true impulse.

Two types of shock simulations are capable of generating near true-impulses

a) Close-range pyrotechnic shock

In pyrotechnic shock, the process of explosion involves chemical reactions in a substance which convert the explosive material into its gaseous state at very high temperature and pressure. Most explosives, such as Flexible Linear Shaped Charge and pyrotechnic bolts, do not contain as much energy as ordinary fuel, but generate extremely high rate of energy release during the explosion. The response of the structure near the immediate region can actually approach a true impulse due to the instantaneous velocity change at the explosive interface. As a result, measuring at the area surrounding a pyrotechnic explosion has always been a nightmare for engineers and scientists.

Depending on the explosive location and the point of measurement, the amount of high frequency energy reaching the transducer is inversely proportion to the distance between them. In a remote sensing location where the shock wave has to propagate through a long path or many joints of dissimilar materials to reach the transducer, high frequency components can be significantly attenuated.

b) Close-range (near-field) metal-to-metal Impact

Most pyroshock simulation devices, such as drop towers and pneumatic hammers, rely on high velocity metal-to-metal impact to generate the required shock spectrum. When the point of contact allows very little material deformation (like in all reusable shock machines), the acceleration response of the structure can also approach a true impulse. Again, the input spectrum is highly dependent upon the accelerometer location relative to the point of impact.

Effect of near true-impulses on accelerometer

Although these common methods of shock simulation present a formidable challenge for the entire measurement system — from sensor to data capture; the accelerometer is by far most vulnerable under such conditions. There are two types of widely used shock accelerometers; piezoresistive and piezoelectric devices. Each reacts differently under the attack of near true-impulses. Three common failure modes are observed:

a) Sensor Failure

Recent new designs in piezoresistive accelerometer have tremendously improved their usable bandwidth and rigidity. One type of commercially available PR sensor exhibits seismic resonance above 1 MHz [3], leaving quite a margin of safety for the general rule-of-thumb. Under the attack of true impulses, however, the sensor can still be set into resonance (at 1 MHz) due to the nature of the input signals. Since the gage mechanism is practically undamped, displacement of the elements goes out of control at resonance and eventually cause permanent gauge damage. The result of this type of failure is complete loss of data.

Piezoelectric sensors are more robust under the same condition. But they fail in other fashions:

b) Zeroshift

This subject has been well examined in many technical papers [4] [5] [6]. A piezoresistive accelerometer generally does not exhibit zeroshift until the gauge mechanism has been damaged or is in the process of deterioration. Piezoelectric sensors, on the other hand, account for most of the zeroshift phenomena associated with transducers.

When a piezoelectric element is set into resonance, two things can happen:

1. Relative displacement of the sensing element at its resonance can exceed 100 times of the input. Internal stress at the molecular level is therefore unusually high. This overstress condition produces spurious charge

outputs due to domain switching, a characteristic common in polycrystalline materials. The result of this type of phenomenon is DC offset in the time history, as shown in Figure1.

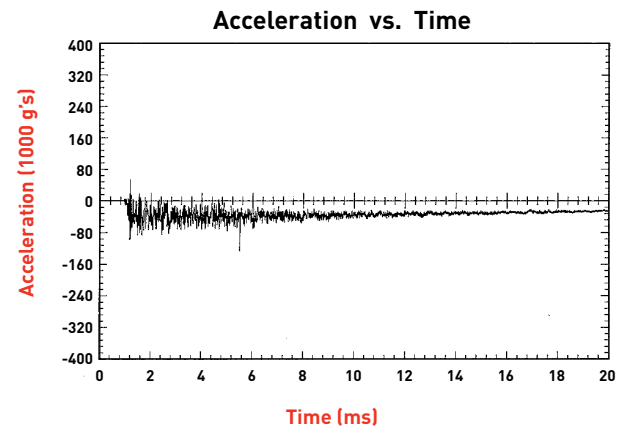
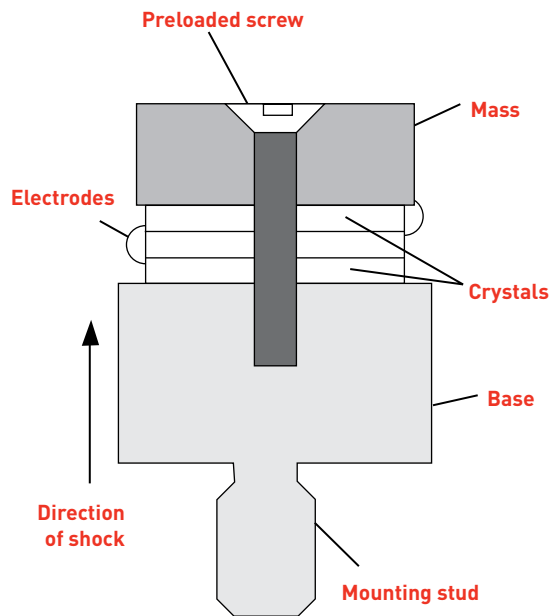

Figure 1.

2. Crystal elements that have monocrystalline structure do not exhibit domain switching phenomenon, but they produce zeroshift in another fashion. Most monocrystal (such as quartz) shock accelerometers are compression type design, as depicted in Figure 2. In this type of design, the sensor assembly is held together by a preloaded screw. When the transducer is excited into resonance, the amount of relative displacement between the components can actually result in shifting of their original positions. These physical movements of sensor parts cause a sudden change in the preload condition and manifest itself as a hysteresis effect — zeroshift at the output.

3. The crystal material is not overstressed, and no physical shifting of parts occurred, but a huge amount of charge output is generated simply due to sensor resonance. This unexpected amount of electrical signal can saturate, or in many instances, damage the subsequent signal conditioners. The result of this type of malfunction is loss of data or gross DC offset in the time history.

Slight amount of zeroshift in the time history can yield unrealistic velocity and displacement during data



Compression accelerometer design

Figure 2.

reduction. The real danger remains that, although data with gross DC offsets are generally discarded, the minor offsets in the acceleration data (mostly unnoticeable by naked eyes) are accepted as good measurements.

c) Non-linearity

The output of a transducer at resonance is sometime non-linear and not repeatable. The response of a saturated charge converter is also non-linear and not repeatable. The result of this type of malfunction is poor repeatability in SRS, leading to incorrect definition of the shock environment.

Solution to the problem — Mechanical filter

Mechanical filter

An obvious solution to the accelerometer resonance problem is to isolate the sensor from high frequency inputs. When an appropriate material is placed between the structural mounting surface and the transducer, a mechanical low-pass filter is formed. The filter slope of such an arrangement approaches 12 dB per octave.

In order to make the filter effective, the -3 dB corner must be set at a frequency far below the accelerometer resonance to insure adequate attenuation.

There are four critical design parameters in a mechanical filter:

- 1) First, the filter/accelerometer combination must be robust enough to withstand high level shocks. Many "isolators" designed for vibration isolation will simply disintegrate under shock.
- 2) The Q (amplification) of the mechanical filter must be very low in order to maintain and maximize frequency response linearity. Damping characteristic is a critical consideration in matching the accelerometer to the mechanical filter.
- 3) The relative displacement between the transducer and the mounting surface must not exceed the linear range of the spring/damper. When the accelerometer "bottoms out", its high frequency isolation characteristic of the filter vanishes, and the protection to the sensor fades.
- 4) The transfer characteristics of the mechanical filter must be clearly defined. The result has to be repeatable and predictable.

Existing designs

Although there many shock isolators on the market for machine vibration isolation, they are not designed with linearity in mind, and their applications are quite different. A few international and U.S. private institutions have developed some experimental devices for their own shock measurements, but none are commercially available. These prototypes are made out of exotic materials, such as rosewood and cloth, for their unique damping and stiffness properties. Reliability and repeatability of these external filters are questionable at best. One of the accelerometer manufacturers does offer an external mechanical filter especially tuned for its own brand of transducers, but it is really intended for a general vibration environment.

One common problem facing external mechanical filters is the resonance of the filter itself. Even with careful selection of spring and damping materials, critical damping is rarely achieved. Any small amount of amplification factor (Q) in an imperfectly damped filter will produce substantial degree of amplitude distortion from a shock input. This distortion manifests itself as ringing (at the filter's corner frequency) superimposed on the accelerometer output signals.

Another problem has to do with accelerometer matching. The corner frequency and the Q of a external filter is highly sensitive to the mass of the attached transducer. Minor deviation on size and weight can result in significantly different response.

Given the physics of the problem discussed above, it seems obvious that if one can first design a shock transducer to incorporate an internal mechanical filter for sensor isolation, and match it with a built-in electronic low-pass filter to remove unwanted residual ringing, many fundamental problems in shock accelerometer design can be solved. A block diagram in Figure 3 depicts this concept.

Built-in Mechanical Filter

Endevco® has successfully designed and manufactured a shock accelerometer with built-in mechanical filter. This product was introduced in 1990, and the feedbacks and responses have been very positive.

Based on a well-established piezoelectric shock sensor, this accelerometer features a captive mechanical filter arrangement. Compared to the model of an

external filter (Figure 4a), this unique design gives the transducer/filter system the needed, and provides mechanical isolation to the sensor (m) from all sides. (see Figure 4b) High frequency energy, in the sensitive and transverse directions, is filtered by the isolation material, leaving the sensing element with only the pass-band signals. In addition, the transducer's external housing keeps the entire assembly together in case of excessive shock input.

Figure 4a.

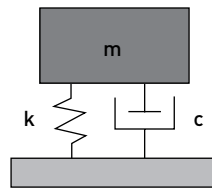

External mechanical filter model

Figure 4b.

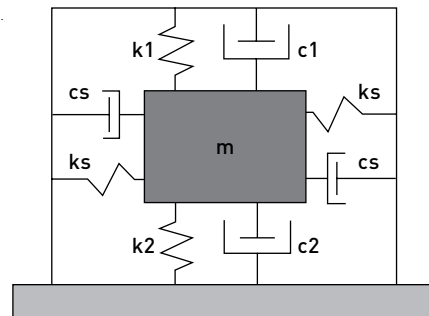

Internal mechanical filter model

The light-weight sensor assembly (m) houses the piezoelectric element and the hybrid microelectronics. The internal electronic filter, a two-pole Butterworth low-pass, provides another 12 dB per octave roll-off after the mechanical filter. The spring/damping (k & c) is meticulously chosen and matched to react with the mass

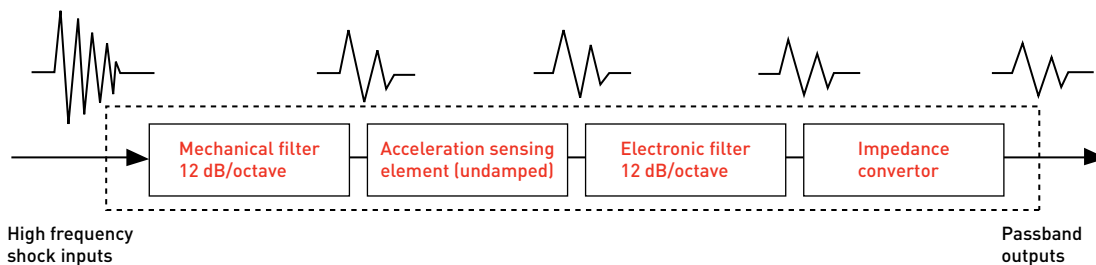

Model for accelerometer with built-in mechanical filter

Figure 3.

of the sensor in a synergistic fashion. This combination yields a mechanical filter with a damping coefficient of .20 to .15, and a resonant frequency of 15 kHz in the sensing direction.

To attenuate the ~5 dB rise at 15 kHz, the corner of the 2-pole low-pass filter is purposely set at 10 kHz in order to compensate for this unwanted peak.

The end result is shown in Figure 5 where the solid line represents the combined frequency response of the accelerometer; the single dotted line represents the mechanical filter response, and the double dotted line denotes the electronic filter response. This combination offered a 24 dB per octave roll-off beyond 10 kHz which effectively isolated the piezoelectric element and subsequent electronics from any high frequency transient. Built-in electronics also allowed impedance conversion taking place inside the transducer, a desirable feature for signal transmission.

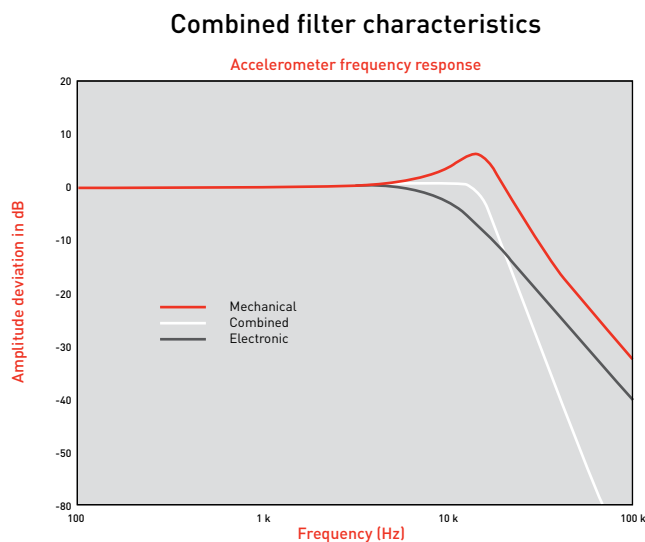

Figure 5.

Accelerometer performance

Frequency response calibration of a sample accelerometer is shown in Figure 6. The accelerometer has an effective linear amplitude response from 1 Hz to 10 kHz within ± 1 dB. Sensitivity of the unit is 0.12 mV/g

which equates to a full scale dynamic range of $\pm 50\,000g$. Transverse sensitivity up to 50 000 g is less than 5%, and the resonance of the crystal element itself is larger than 130 kHz. The accelerometer weights 5.0 grams and operates from a constant current source.

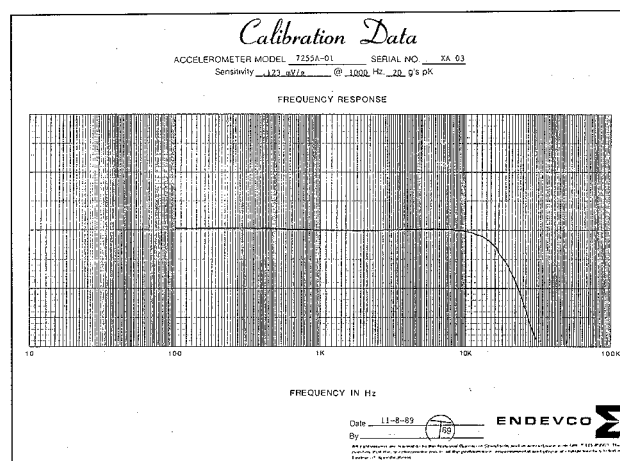

Figure 6.

One of the major concerns regarding the performance of the transducer has been temperature response. Since the material used for spring/damper is basically a polymer, damping characteristics varied with temperature. An experiment was conducted to determine the effect of temperature on output sensitivity using transient inputs from a Hopkinson bar. The input transient was defined to be about 100 000 g peak half-sine, and the corresponding pulse width was $\sim 70 \mu s$. Repeatability of the pulse shape was quite acceptable, but the shock level had a standard deviation of 5 500 g.

Figure 7 compares the transient responses of the accelerometer at 75°F (24°C) and 45°F (7°C). The peak response at 75°F is measured to be 86 000 g, and 78 100 g at 45°F (7°C) (these are median data selected from samples at approximately the same level). The peak level is considerably less than 100 000 g due to filter attenuation. Taking the variability of input level into account, the indicated peak g at 45°F is 9.2% lower than at room temperature.

Transient response at temperature

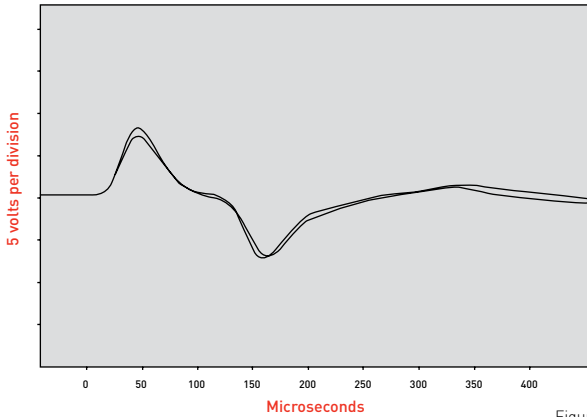

Figure 7.

Figure 8 shows the transient responses at 75°F (24°C) and 120°F (49°C). Here the indicated peak g at 120°F (49°C) is 83 000 g, and 79,000 g at 75°F (24°C), a +5.0% increase in amplitude response.

Transient response at temperature

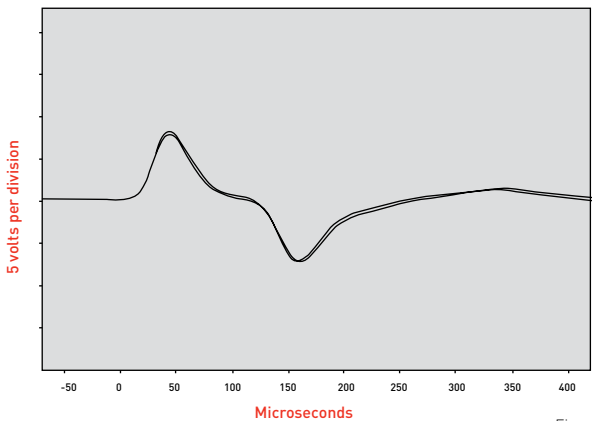

Figure 8.

Pushing the physical limit of the damping material, the same test was conducted at 150°F (66°C). Figure 9 shows the transient responses at 75°F (24°C) and 150°F (66°C). At 150°F (66°C), the peak response indicates 100,700 g while the 75°F (24°C) shows 84 000 g, a +19.9% increase in apparent response. Our data seems to indicate that, within ±30°F (±17°C) from ambient temperature 75°F (24°C), the mechanical filter displays a small amount of variation. Above 120°F (49°C), however, some correction factor may be necessary.

Transient response at temperature

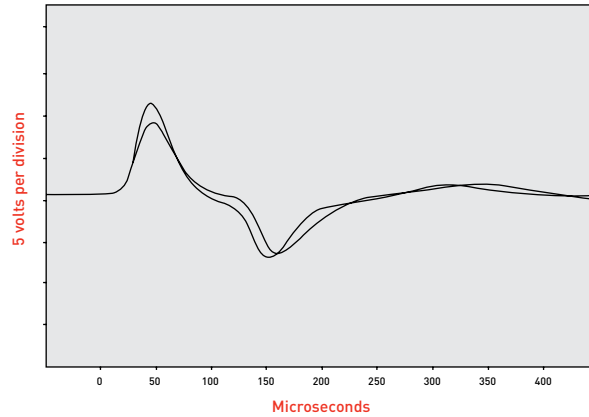

Figure 9.

Design limitation

Apart from the temperature constraint mentioned in the preceding section, the accelerometer has another physical limitation. Referring to Figure 4b. The mass (m), in our design, is the sensor of the accelerometer, and the mounting surface becomes the boundary of this second order system.

The mechanical filter in the sensitive directoin are represented in this model by k1, k2, c1 and c2. As long as the force transmitted to the sensor does not cause excessive travel in k1 and k2, the system will operate in a predictable manner. The practical displacement limit (t) is estimated to be <0.75 mm, in which the material still behaves linearly.

The equation which relates dynamic range of the mechanical filter to the maximum linear travel of the spring material is:

$$\frac{t}{\ddot{x}} = \frac{1}{\omega_n^2 \sqrt{\left[1 - \left(\frac{\omega}{\omega_n}\right)^2\right]^2 + \left(2\zeta \frac{\omega}{\omega_n}\right)^2}}$$

t = maximum travel of spring

\ddot{x} = maximum input acceleration

ζ = damping factor

A maximum input shock spectrum derived from this equation (based on 0.75 mm spring travel and damping of 0.2) is shown in Figure 10. The weakest spot is understandably at 15 kHz where the filter resonates. The maximum allowable level at that frequency is 276 000 g. Above 276 000 g the mechanical filter starts to lose its effectiveness (eg. bottoms out), and protection to the sensor decreases rapidly.

The spring/damper (ks & cs) in the transverse direction are not designed to behave as a quantifiable mechanical filter in conjunction with (m), they are merely acting as an isolators to energy above 10 kHz. Since the sensing element of the accelerometer does not respond to transverse acceleration (it has a <5% transverse sensitivity), this arrangement appears to be more than adequate in protecting the sensor from shock.

Maximum input spectrum, Endevco model 7255A

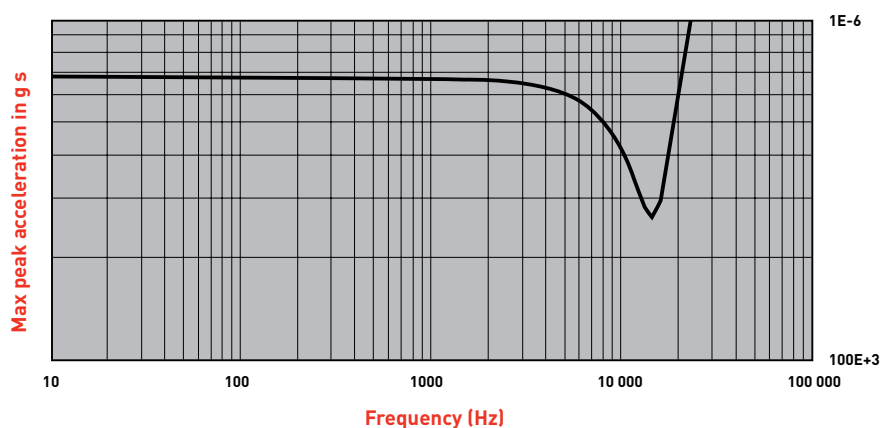

Figure 10.

References

1. A. E. Galef, "The Pre-Pulse in Pyroshock Measurement and Analysis", Bulletin, 56th Shock & Vibration Symposium, Part III, 1986.
2. A. E. Galef, "Zero-shifted Accelerometer Outputs", Bulletin, 56th Shock & Vibration Symposium, Part III, 1986.
3. R. D. Sill, "Shock Calibration of Accelerometers at Amplitudes to 100,000g Using Compression Waves", Proceedings, 29th International Instrumentation Symposium, ISA, 1983.
4. R. H. Plumlee, "Zeroshift in Piezoelectric Accelerometers", Sandia Corporation Report, SC-RR-70-755, 1971.
5. Davis, "Investigation of Zero Shift in Piezoelectric Ceramic Accelerometers", Sandia Corporation Report, 71-631.
6. A. S. Chu, "Zeroshift of Piezoelectric Accelerometers in Pyroshock Measurements", Bulletin, 57th Shock & Vibration Symposium, Part I, 1987.
7. W. S. Walton, "Dynamic Response of Armor Plate to Non-Penetrating Projectile Impact", Bulletin, 56th Shock & Vibration Symposium, Part I, 1986.